



UCP Unified Communication Platform

Overview

The OpenVox Unified Communication Platform (UCP) is an ideal all-in-one solution for small and medium-sized enterprises, integrating data, voice, and video into a single product. Its advanced design combines performance, flexibility, reliability, and availability to deliver exceptional value.

UCP is built around three major components: VoIP voice modules, MCU main control modules, and Ethernet switching modules. Its core concept is to flexibly combine hardware based on business needs and interconnect modules through an Ethernet bus, creating a highly customizable IP voice communications platform. UCP is currently available in four models: 1202, 1600, 2120, and 4131.

Unified Communications Platforms: Product Portfolio



Model: UCP1202



Model: UCP1600



Model: UCP2120



Model: UCP4131

Architecture

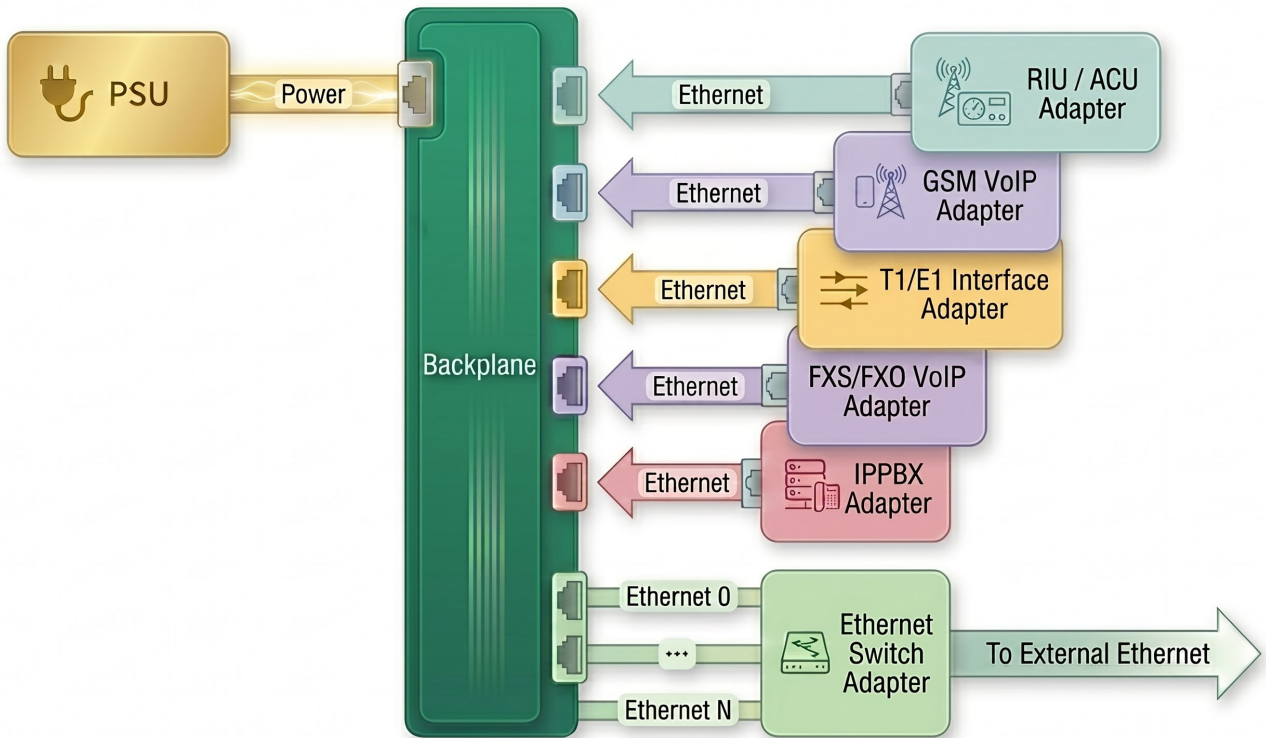

Features

Reliability

- Passive backplane
- Hot-swappable service boards
- Eliminates single points of failure
- Star-topology bus
- High-speed CompactPCI connectors

Availability

- Optional software: FreePBX, 3CX, Issabel, Asterisk, and more
- Modules are easy to install, configure, and remove
- Highly reliable solution

Flexibility

- Choose the right chassis, control, switching, and service modules based on actual deployment needs.

UCP1202 product details



UCP1202 Slot Description

1
2

UCP1202 chassis are manufactured using a sheet metal process

Dimensions: 188 mm (W) x 202 mm (D) x 50 mm (H).

Slot 1 (Main Control): One and only one CCU-N-ALDER main control board (Intel N-series Alder Lake-N quad-core processor) must be installed.

Slot 2 (Service): 1 universal service board slot for expanding voice services.

UCP1202 Unified Communication Platform	
Recommended Users	800
Weight	1.5 kg
Ethernet Ports	2 x Gigabit Ethernet ports
Max Power	36 W
DC Power Adapter	12 V / 2 A
Operating Temperature (Long-Term)	0°C to 45°C
Operating Temperature (Short-Term)	-5°C to 55°C
Storage Humidity	5% to 95%, non-condensing
Storage Temperature	-40°C to 70°C

UCP1600 product details



UCP1600 Slot Description

2	3	5
1	CSU-F/G	4

UCP1202 chassis are manufactured using a sheet metal process and follows a standard 1U rackmount design.

Dimensions: 434 mm (W) x 330 mm (D) x 44 mm (H). It provides 1 main control slot and 4 service board slots.

Slot Description

Slot 1 (Main Control): One and only one CCU-N-ALDER main control board must be installed.

Slots 2-5 (Service): 4 universal service board slots for mixed service board deployments.

UCP1600 Unified Communication Platform

Recommended Users	800
Slots	1 main control slot, 4 service board slots
Weight	3.9 kg
Dimensions	434 mm x 330 mm x 44 mm
Ethernet Ports	CSU-F provides 2 x Fast Ethernet ports by default; upgrade to CSU-G for 3 x Gigabit Ethernet
Max Power	75 W
AC Input	100 V to 240 V AC
Operating Temperature (Long-Term)	0°C to 45°C
Operating Temperature (Short-Term)	-5°C to 55°C
Storage Humidity	5% to 95%, non-condensing
Storage Temperature	-20°C to 70°C

UCP2120 product details

UCP2120 Slot Description



4	7	11
3	6	10
2	5	9
1	CSU-F/G	8

UCP2120 chassis is manufactured using a sheet metal process and is a standard 2U standard rackmount chassis measuring 434mm wide, 330mm deep, and 88mm high. It offers 2 main control board slots and 9 service board slots (2~7,9~11).

Slot Description

Slots 1 and 8: 2 main control slots that support all CCU main control board models. If no main control board is installed in Slot 8, it can be used as a standard service slot.

Slots 2-7 and 9-11 (Service): 9 universal service board slots that support mixed service board deployments for strong expandability.

UCP2120 Unified Communication Platform

Recommended Users	4000
Slots	2 main control slots, 9 service board slots
Weight	5.6 kg
Ethernet Ports	CSU-F provides 2 x Fast Ethernet ports by default; upgrade to CSU-G for 3 x Gigabit Ethernet
Max Power	200 W
Redundant Power	Supported
AC Input (Default)	100 V to 240 V AC
DC Input (Optional)	-48 V to -60 V
Operating Temperature (Long-Term)	0°C to 45°C
Operating Temperature (Short-Term)	-5°C to 55°C
Storage Humidity	5% to 95%, non-condensing
Storage Temperature	-20°C to 70°C

UCP4131 product details

UCP4131 chassis is manufactured using a sheet metal process and is a standard 4U standard rackmount chassis measuring 434mm wide, 330mm deep, and 88mm high. It offers 2 main control board slots and 9 service board slots (2~7,9~11) and redundant power supply options.

Slot Description

Slots 2 and 7: Provides 2 main control board slots to support the installation of all models of CCU main control boards. Slot 7 can be used as an ordinary business slot when the main control board is not installed.

Slots 1, 3-6, and 8-11 (Service): 9 universal service board slots for mixed service board deployments.



UCP4131 Slot Description

1	Service Board
2	Master Control
3	Service Board
4	Service Board
5	Switching Board
6	Service Board
7	Master Control
8	Service Board
9	Service Board
10	Service Board
11	Service Board
12	Power Supply
13	Power Supply

UCP4131 Unified Communication Platform

Recommended Users	4000
Slots	1 main control slot, 9 service board slots
Weight	9.6 kg
Ethernet Ports	CSU-F provides 2 x Fast Ethernet ports by default; upgrade to CSU-G for 3 x Gigabit Ethernet ports
Max Power	400 W
Redundant Power	Supported
AC Input (Default)	100 V to 240 V AC
DC Input (Optional)	-48 V to -60 V
Operating Temperature (Long-Term)	0°C to 45°C
Operating Temperature (Short-Term)	-5°C to 55°C
Storage Humidity	5% to 95%, non-condensing
Storage Temperature	-20°C to 70°C

Module Overview

I. Main Control

Board Model	Interfaces	Recommended Scenario	UCP1202	UCP1600	UCP2120	UCP4131
CCU-I-ALDER	3 x Gigabit Ethernet, 1 x HDMI, 1 x USB 3.0	SME deployments; rec. users < 800, rec. concurrent calls < 200	Yes	Yes	Yes	Yes
CCU-I-TGL	3 x Gigabit Ethernet, 1 x HDMI, 2 x USB 3.0, 1 x RST	High-density / high-capacity deployments; rec. users < 4000, rec. concurrent calls < 800	No	No	Yes	Yes

II. Switching

Board Model	Interfaces	Recommended Scenario	UCP1202	UCP1600	UCP2120	UCP4131
CSU-G	3 x Gigabit Ethernet, 1 x SFP	High-speed Gigabit switching for high-throughput traffic	No	Yes	Yes	Yes
CSU-F	2 x Fast Ethernet, 1 x CONSOLE, 1 x RST	Entry-level switching with strong cost performance	No	Yes	Yes	Yes

Module Overview

III. Service Boards

Board Model	Interfaces	Recommended Scenario	UCP1202	UCP1600	UCP2120	UCP4131
AIU-8	8 x FXO, 8 x FXS, or 4 x FXO + 4 x FXS	Small to medium analog voice access	Yes	Yes	Yes	Yes
AIU-16	16 x FXS	High-density analog voice access	Yes	Yes	Yes	Yes
RIU	2/4 wireless interfaces	Wireless link access and expansion	Yes	Yes	Yes	Yes
ACU	2 audio input/output groups	Audio input/output access	Yes	Yes	Yes	Yes
DTU	1/2/4 x E1/T1/J1	High-capacity concurrent calling	Yes	Yes	Yes	Yes
MIU	4 Four-way magnet telephone interface	electric power, railways, mines, and factories that require one-click calls and direct access to dedi-	Yes	Yes	Yes	Yes
WTU	4 x GSM/LTE	Wireless access, mobile-network backhaul, and cellular voice access	Yes	Yes	Yes	Yes
SEU	1 x SATA	Storage expansion, local logs/recordings/data, and system	No	Yes	Yes	Yes
RSU	/	Highest reliability with dual SEU boards using RAID1 data	No	No	No	Yes



OpenVox Communication Co., Ltd.
Website: www.openvoxtech.com

Address: 2nd Floor, Building I, Jinchangda Science and Technology Park, Shangwei Village, Zhangkengjing, Guanhu Street, Longhua District, Shenzhen, Guangdong 518110

Copyright © OpenVox Communication Co., Ltd. All rights reserved.